

# MODEL : LC-208 [ Flange Lift Check Valve ]

Connection : PN 16, PN 40



**VTV VALVE**, serving Multi-National end users in a wide range of applications in many industries including:

1. Palm Oil and Refinery Plant
2. Food Industries
3. Petrochemical Plant
4. Cooling System
5. Heating

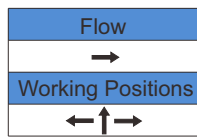

- ◆ **Suitable for :**
  1. Water
  2. Steam
  3. Oil
  4. Gases
  5. Non-abrasive media

### ◆ SPECIFICATION

Standard PN16 ~ 40, DN15 ~ 300  
Design and manufacture : DIN3356

### ◆ PRESSURE / TEMPERATURE RATING

PN 16 : 16 bar - 120°C | 13 bar - 200°C | 10 bar - 300°C  
PN 40 : 40 bar - 100°C | 35 bar - 200°C | 28 bar - 300°C

### ◆ MATERIAL LIST

No	Parts Name	Material	
		PN16	PN40
1	Body	Cast Iron (FC200)	Cast Steel (WCB)
2	Disc	SS410	SS410
3	Seat Ring	SS410	SS410
4	Spring	SS304 (CF8)	SS304 (CF8)
5	Bonnet	Cast Iron (FC200)	Cast Steel (WCB)
6	Bolt	Cast Iron (FC200)	Cast Steel (WCB)
7	Nut	Cast Iron (FC200)	Cast Steel (WCB)

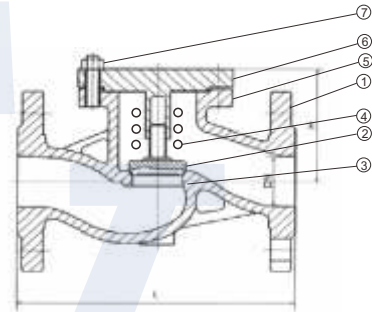

### ◆ DIMENSIONS (mm)

DN	15	20	25	32	40	50	65	80	100	125	150	200	250	300	
L	130	150	160	180	200	230	290	310	350	400	480	600	730	850	
H	70	70	80	80	85	95	110	130	155	165	215	285	325	365	
Weight	PN16	2.4	3	3.8	5.7	7.4	10.5	15.2	20.5	31	49	69	133	198	278
	PN40	4	5	6	7	10	12.5	22.7	28.5	40	64	90	170	240	370

Specification is subject to change without prior notice