

MODEL : JF400 [Expansion Joint]

Connection : Flange PN 16, PN 40, ANSI 150, ANSI 300

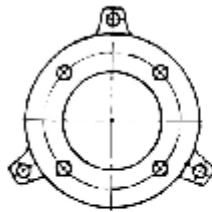

SEE BELOW FOR NUMBER OF RODS

VTV BELLOWS CONNECTORS WITH TIE RODS

The Bellow Pump Connector, which is kept stocked to 14" for fast delivery, is designed to meet a broad set of needs. It has a 2-ply construction and tie rods that allow it to work well, and economically, in many situations.

- 150 F Maximum Working Pressure. 225 psi
- 212 F Maximum Working Pressure. 190 psi
- 480 F Maximum Working Pressure. 110 psi

SIZE	SHORT/ LONG*	COMPRESSION*			FLANGED ENDS						WELD ENDS					
		50 psi (in)	150 psi (in)	300 psi (in)	50 psi		150 psi		300 psi		50 psi		150 psi		300 psi	
					OAL (in)	WT (lbs)	OAL (in)	WT (lbs)	OAL (in)	WT (lbs)	OAL (in)	WT (lbs)	OAL (in)	WT (lbs)	OAL (in)	WT (lbs)
2"	S	1-1/8	1-1/8	3/4	6-1/2	11	6-1/2	11	6-1/2	12	9-7/8	3	9-7/8	3	9-7/8	3
	L	1-3/4	1-3/4	1-1/4	8-1/2	13	8-1/2	13	8-1/2	14	11-3/4	4	11-3/4	4	11-3/4	4
2-1/2"	S	1	1	3/4	7	14	7	14	7	16	9-7/8	3	9-7/8	3	9-7/8	3
	L	1-3/4	1-3/4	1-1/4	8-7/8	16	8-7/8	16	8-7/8	17	11-3/4	4	11-3/4	4	11-3/4	4
3"	S	1	1	3/4	7-3/8	17	7-3/8	20	7-3/8	21	10-1/2	5	10-1/2	5	10-1/2	5
	L	2	2	1-3/8	9	18	9	21	9	22	12	6	12	6	12	7
4"	S	1-1/4	1-1/4	7/8	7-1/2	27	7-1/2	35	7-1/2	37	10-5/8	8	10-5/8	8	10-5/8	9
	L	2-1/2	2-1/2	1-3/4	10-3/4	28	10-3/4	36	10-3/4	40	13-3/4	9	13-3/4	9	13-3/4	10
5"	S	1-1/4	1-1/4	3/4	7-5/8	33	7-5/8	45	7-5/8	47	10-5/8	13	10-5/8	13	10-5/8	14
	L	2-1/2	2-1/2	1-3/4	11-1/4	34	11-1/4	49	11-1/4	51	14-1/4	15	14-1/4	15	14-1/4	17
6"	S	1-1/4	1-1/4	3/4	8	43	8	85	8	89	11	18	11	16	11	20
	L	2-1/2	2-1/2	1-3/4	11-1/2	47	11-1/2	90	11-1/2	94	14-1/2	20	14-1/2	20	14-1/2	22
8"	S	1-1/2	1-1/2	1	9-1/4	64	9-1/4	120	9-1/4	126	12-1/8	22	12-1/8	22	12-1/8	24
	L	3	3	2	13-1/4	71	13-1/4	125	13-1/4	131	16-1/8	26	16-1/8	26	16-1/8	29
10"	S	1-1/2	1-1/2	1	9-3/8	45	9-3/8	160	9-3/8	166	12-1/8	23	12-1/8	23	12-1/8	27
	L	3-3/8	3-1/4	2-1/2	14-3/8	52	14-3/8	170	14-3/8	176	17-1/4	32	17-1/4	32	17-1/4	35
12"	S	1-1/2	1-1/2	1	9-3/4	70	9-3/4	200	9-3/4	210	12-1/2	33	12-1/2	33	12-1/2	39
	L	3-1/4	3-1/8	2-1/4	13-1/2	85	13-1/2	220	13-1/2	231	16-1/4	42	16-1/4	42	16-1/4	46
14"	S	1-3/4	1-1/2	1	10-3/8	98	10-3/8	220	10-3/8	386	14-1/8	56	14-1/8	56	14-1/8	132
	L	3-1/2	3	2	15	112	15	210	15	414	18-3/4	70	18-3/4	88	18-3/4	150
16"	S	1-3/4	1-1/2	1-1/2	11-1/4	112	11-1/4	232	11-1/4	440	15	62	15	66	15	92
	L	3-1/2	3	3	16-3/4	127	16-3/4	250	16-3/4	470	20-1/2	77	20-1/2	86	20-1/2	122
18"	S	1-3/4	1-1/2	1-1/2	11-1/2	112	11-1/2	256	11-1/2	554	15	57	15	71	15	99
	L	3-1/2	3	3	17	123	17	314	17	536	20-1/2	68	20-1/2	80	20-1/2	131
20"	S	1-3/4	1-1/2	1-1/2	13-3/8	130	13-3/8	378	13-3/8	710	15	72	15	86	15	113
	L	3-1/2	3	3	18-7/8	146	18-7/8	402	18-7/8	750	20-1/2	88	20-1/2	112	20-1/2	173
22"	S	1-3/4	1-1/2	1-1/2	14	140	14	426	14	630	15	78	15	100	15	132
	L	3-1/2	3	3	19-1/2	157	19-1/2	454	19-1/2	675	20-1/2	95	20-1/2	128	20-1/2	202
24"	S	1-3/4	1-1/2	1-1/2	14-1/4	220	14-1/4	465	14-1/4	1030	15	88	15	116	15	180
	L	3-1/2	3	3	19-3/4	240	19-3/4	520	19-3/4	1070	20-1/2	106	20-1/2	150	20-1/2	220
30"	S	1-3/4	1-1/2	-	9	370	9	**	-	-	11-1/2	125	11-1/2	196	-	-
	L	3-1/2	3	-	14-1/2	405	14-1/2	**	-	-	17	162	17	264	-	-
36"	S	1-3/4	1-1/2	-	9	575	9	**	-	-	11-1/2	180	11-1/2	236	-	-
	L	3-1/2	3	-	14-1/2	625	14-1/2	**	-	-	17	230	17	315	-	-
42"	S	1-3/4	1-1/2	-	9	770	9	**	-	-	11-1/2	206	11-1/2	266	-	-
	L	3-1/2	3	-	14-1/2	830	14-1/2	**	-	-	17	355	17	355	-	-
48"	S	1-3/4	1-1/2	-	10-1/2	970	10-1/2	**	-	-	11-1/2	320	11-1/2	390	-	-
	L	3-1/2	3	-	16	1030	16	**	-	-	17	420	17	420	-	-

Specification is subject to change without prior notice

Tube End Type - JF-250 Series (One ply bellows for medium pressure) JF-400 Series (Multiply bellows for high pressure)

Feature

Stainless steel bellows welded with tube end or threaded tube end. Internal sleeve is optional. Designed to accommodate axial movement of pipeline in medium (JF-250series) and high (JF-400series) working pressure and high working temperature.

CONSTRUCTION

Item	Parts	250SP	250P	250ST	400SP	400P	Material
1	Bellows	☉	☉	☉	☉	☉	SUS304/SUS316
2	Internal Sleeve	☉		☉	☉		SUS304/SUS316
3	Tube End	☉	☉	☉	☉	☉	SS400/SUS304/SUS316
4	Threaded Tube End			☉			SS400/SUS304/SUS316

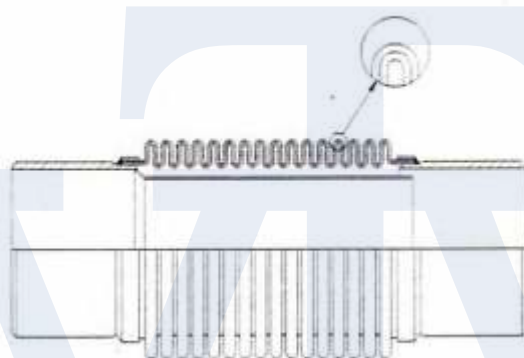

Installation

Heating no need elongation to getting compression 50 mm. or 75 mm.
Cooling need compression 50 mm. or 75 mm. to getting expansion 50 mm. or 75 mm.

Specification

Nominal Bore		Total Length		Bellows				Axial Movement		Working Pressure		Axial Spring Rate	Effective Area	
mm	inch	mm	inch	O.D.	CORR.	PLY	No.	mm	inch	bar	psi	N/mm	cm ²	inch ²
40	1 1/2	360	14.17	58.0	2.28	2	32	-50	2	25	363	29.00	20.2	3.1
		515	20.28				48	-75	3			19.34		
		360	14.17				24	-50	2			44.25		
50	2	515	20.28	73.0	2.85	2	36	-75	3	25	363	29.50	32.1	5.0
		360	14.17				20	-50	2			89.82		
		515	20.28				30	-75	3			59.88		
65	2 1/2	360	14.17	90.0	3.54	2	20	-50	2	25	363	81.54	49.1	7.6
		515	20.28				30	-75	3			59.88		
		360	14.17				20	-50	2			81.54		
80	3	515	20.28	104.5	4.11	2	30	-75	3	25	363	54.36	67.4	10.5
		360	14.17				16	-50	2			146.06		
		515	20.28				24	-75	3			97.37		
100	4	360	14.17	132.0	5.20	2	15	-50	2	25	363	161.14	108.9	16.9
		515	20.28				24	-75	3			97.37		
		360	14.17				15	-50	2			161.14		
125	5	515	20.28	161.0	6.34	2	23	-75	3	25	363	105.33	167.1	25.9
		360	14.17				14	-50	2			192.81		
		515	20.28				21	-75	3			128.54		
150	6	360	14.17	190.0	7.48	2	14	-50	2	25	363	192.81	239.2	37.1
		515	20.28				21	-75	3			128.54		
		360	14.17				13	-50	2			264.16		
200	8	515	20.28	250.0	9.84	2	19	-75	3	16	232	179.99	420.9	65.2
		360	14.17				13	-50	2			264.16		
		515	20.28				19	-75	3			179.99		
250	10	360	14.17	312.0	12.28	2	12	-50	2	16	232	428.99	644.6	103.0
		515	20.28				18	-75	3			285.99		
		360	14.17				12	-50	2			499.81		
300	12	515	20.28	364.5	14.35	2	18	-75	3	16	232	333.21	925.4	143.4
		360	14.17				12	-50	2			499.81		
		515	20.28				18	-75	3			333.21		

Other movements, sizes, and pressure expansion joint available on request

Pressure Temperature rating with ISO - 15348						
Bar	Temperature in degree C					
	-120 °C	150 °C	200 °C	250 °C	300 °C	350 °C
PN25	25	22.85	20.89	19.58	18.61	17.62
PN16	16	14.62	13.37	12.53	11.91	11.28

Specification is subject to change without prior notice