

MODEL : FV-301 Cast Iron [Flange Foot Valve]

Connection : Flange JIS 10K



VTV VALVE, serving Multi-National end users in a wide range of applications in many industries including:

1. Palm Oil and Refinery Plant
2. Petrochemical
3. Water Treatment Plant
4. Cooling System

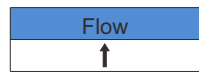

- ◆ **Suitable for :** 1. Water
2. Oil
3. Non-abrasive media

◆ DESCRIPTION

- Working Temperature : $\leq 150^{\circ}\text{C}$
- Flange Dimensions : DIN 2532/2533
other flange standard available.
available for the without valve seal plate type also.

◆ MATERIAL LIST

Parts Name	Material
Body	Cast Iron
Seat	Cast Iron
Seal Plate	Cast Iron
Sealing Gasket	Rubber
Bolt/ Nut	Carbon Steel
Valve Guide Disc Guide	Cast Brass
Screen	Stainless Steel

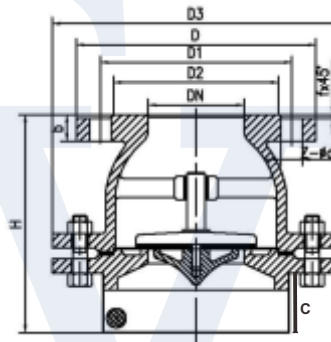

◆ DIMENSIONS (mm)

DN	D	D1	D2	D3	b	Z-Φd	f	C	H	kg
40	150	110	88	170	18	4-18	3	52	138	6.8
50	165	125	102	180	20	4-18	3	68	158	8.83
65	185	145	122	200	20	4-18	3	72	172	11.1
80	200	160	138	240	22	4-18/8-18	3	88	186	15
100	220	180	158	270	22/24	8-18	3	125	245	19.93
125	250	210	188	310	24/26	8-18	3	148	263	28.5
150	285	240	212	360	24/26	8-23	3	178	343	44.1
200	340	295	268	440	26/30	8-23/12-23	3	220	421	60.9
250	395/405	350/355	320	520	28/32	12-23/12-27	3	219	469	83.3
300	445/460	400/410	370/378	590	28/32	12-23/12-27	4	305	609	119.2
350	505/520	460/470	430/438	520	30/36	16-23/16-27	4	520	780	148.2

Specification is subject to change without prior notice