

LINEAR ELECTRIC ACTUATORS
Type EL

EL12, EL20, EL45, EL80, EL120, EL250

DESCRIPTION

Electric linear actuators EL series for modulating and open-close duty of control and process technology to operate control valves.

The self-locking stem/stem nut is driven by an electric motor via a gearing. Load and limit switches define the stops for the end positions.

MAIN FEATURES

- Valve protection against excessive force due to load-dependent seating.
- Comfortable manual operation when disengaging the actuator motor.
- Mounting to valve made via yoke or mounting flange DIN 3358. The design enables easy connection to all types of valves. Standard version is suitable for Adcatrol valves.
- Generating a defined closing force in the end position leads to constantly tight shut-off of the valve.
- A robust metal cover protects efficiently against external contamination and manipulation.
- The actuators are in enclosure protection IP 65 (EL12 IP43) and are designed for rugged industrial use.
- Stall proof synchronous motors (or brake motors for higher positioning forces) ensure highest positioning accuracy.
- Mechanical stroke indication via anti-rotation bar.
- Exact, backlash-free measurement of actual valve stroke by direct coupling to the valve stem.
- Universally usable actuators due to control via 3-point-step controllers, analogue input signals (0...10 V, 0 (4)...20 mA), or fieldbus systems.
- Easy supplement to actuator with optional devices due to modular design.
- Limit switches, easily adjustable, for stroke limitation (not necessary for Adcatrol valves) or as signal for intermediate positions.
- Integrated, adjustable stroke setting to nominal stroke over the complete stroke range (without exchanging pinions, ...).



TECHNICAL DATA						
Type		EL12	EL20	EL45	EL45.1	EL45.2
Positioning force	kN	1,2	2,0		4,5	
Positioning speed ¹⁾	mm/min (mm/s)	8 (0,14)	15 (0,25)	17 (0,28)	25 (0,4)	50 (0,8)
Power consumption (230 V)	A	4	6,6	28	28	32
Nominal current (230 V)	A	0,017	0,029	0,135	0,135	0,160
Type of motor ³⁾		syn	syn	syn	syn	syn
Motor protection ⁴⁾		B	B	B	B	B
Max. stroke	mm	35 mm	75 (standard 55mm)			
Supply voltages ²⁾		24 V / 115 V / 230 V / 400 V 50/60 Hz, 24 V DC				
Type of duty acc. to IEC 34-1		S1 – 100%		S4 – 30% c.d.f. 600 c/h		
Cable entry		3 x M16 x 1,5		2 x M16x1.5 and 1 dummy plug M16x1.5		
Electrical connection		Inside terminal board, terminal configuration according to electrical connection wiring diagram				
Switch off in end position		2 load-dependent switches, max. 250 V AC, rating for resistive load, max. 5 A, for inductive load, max. 3 A				
Mounting position		as desired, however downward position not possible				
Ambient temperature		-20 °C to +60 °C				
Lubricant for gearing		Klüber Mickrolube GL 261 grease				
Position indicator		by anti-rotation bar				
Manual adjustment		crank handle	by means of lateral hand wheel			
Enclosure protection acc. to EN 60529		IP 43	IP 65			
Trapezoidal thread		Tr 8 x 1,5	Tr 14 x 3			
Connection type		EN ISO 5210 F05 (also refer to options)				
Weight	kg	2,1	8,0			

TECHNICAL DATA							
Type		EL80	EL80.1	EL80.2	EL120	EL120.1	EL120.2
Positioning force	kN	8,0			12		
Positioning speed ¹⁾	mm/min (mm/s)	13,5 (0,2)	25 (0,4)	50 (0,8)	13,5 (0,2)	25 (0,4)	50 (0,8)
Power consumption (230 V)	A	25	34	152	25	34	152
Nominal current (230 V)	A	0,11	0,15	0,78	0,11	0,15	0,78
Type of motor ³⁾		syn	syn	asyn	syn	syn	asyn
Motor protection ⁴⁾		B	B	T	B	B	T
Max. stroke mm		80					
Supply voltages ²⁾		24 V / 115 V / 230 V / 400 V 50/60 Hz, 24 V DC					
Type of duty acc. to IEC 34-1		S4 – 30% c.d.f. 600 c/h					
Cable entry		2 x M16x1.5 and 1 dummy plug M16x1.5					
Electrical connection		Inside terminal board, terminal configuration according to electrical connection diagram					
Switch off in end position		max. 3 A					
Mounting position		as desired, however downward position not possible					
Ambient temperature		-20 °C to +60 °C					
Lubricant for gearing		Klüber Microlube GL 261 grease					
Position indicator		by anti-rotation bar					
Manual adjustment		by means of lateral hand wheel					
60529		IP 65					
Trapezoidal thread		Tr 20 x 4					
Connection type		DIN 3210 G0 (also refer to options)					
Weight	kg	13,0					

Specification is subject to change without prior notice

TECHNICAL DATA						
Type	-	-	-	-	EL250.1	EL250.2
Positioning force	kN	-	-	-	25	
Positioning speed ¹⁾	mm/min (mm/s)	-	-	-	25 (0,4)	50 (0,8)
Power consumption (230 V)	A	-	-	-	157	218
Nominal current (230 V)	A	-	-	-	0.73	1.0
Type of motor ³⁾		-	-	-	asyn	asyn
Motor protection ⁴⁾		-	-	-	T	T
Max. stroke mm		100				
Supply voltages ²⁾		115 V / 230 V 50/60 Hz, 24 V DC				
Type of duty acc. to IEC 34-1		S4 – 30% c.d.f. 600 c/h				
Cable entry		2 x M20x1.5 and 1 dummy plug M20x1.5				
Electrical connection		Inside terminal board, terminal configuration according to electrical connection diagram				
Switch off in end position		max. 3 A				
Mounting position		as desired, however downward position not possible				
Ambient temperature		–20 °C to +60 °C				
Lubricant for gearing		Klüber Microlube GL 261 grease				
Position indicator		by anti-rotation bar				
Manual adjustment		by means of lateral hand wheel				
60529		IP 65				
Trapezoidal thread		Tr 26 x 5				
Connection type		DIN 3210 G0 (also refer to options)				
Weight	kg	19,0				

1) at 60 Hz, the positioning speeds and input power increase by 20%
2) other supply voltages on request

3) syn synchronous motor
asyn asynchronous motor
4) B stallproof motor

ACCESSORIES AND OPTIONS		
Accessories for actuators		
Yoke for adaptation to valves refer to dimension sheet.		STALA/FLA
Mounting flange with central attachment Mxx refer to dimension sheet (thrust rod must be secured against revolving).		ZFLA
Compact plug 10/24 poles with additional housing at actuator Voltages ≤ 600 V.		KS
Special finish coating for use in the tropics "tropics coating".		LA-TR
Version with bellows at thrust rod (for EL20, EL45, EL80, EL120).		A-FAB

Options for actuators		
Additional limit switches for signalling end positions or intermediate positions, freely adjustable, max. 250 V AC, rating for resistive load max. 5 A, for inductive load max. 3 A, max. 2 switches for EL20 and EL45, max. 4 switches for EL80 and EL120.		WE
Additional limit switches for signalling end positions or intermediate positions, freely adjustable, with gold-plated contacts for low voltage, max. 30 V AC, rating for resistive load max. 0.1 A, max. 2 switches for EL20 and EL45, max. 4 switches for EL80 and EL120.		WE-G
Potentiometer 100/130/200/500/1000/5000 Ohms or 10 kOhms Linearity error ≤ 0.5 %, max. 1.5 W, contact current 30 mA max. 2 pieces		POT
Electronic position feedback 2-/3-/4-wire system Inductive travel measuring, output 0 (4)...20 mA Connection 24 V DC		ESR
Positioning electronics for actuator control Input 0...10 V, 0 (4)...20 mA, output 0...10 V, 0 (4)...20 mA Supply voltage 24, 115, 230 V 50/60 Hz		PEL
Heating resistor with thermoswitch against moisture with automatic temperature regulation, max. 15 Watts Supply voltage 24, 115, 230 V 50/60 Hz		HZ/WP

Specification is subject to change without prior notice

ELECTRICAL CONNECTION

3 - asynchronous motor with brake and thermoswitch	1 - asynchronous motor with brake and thermoswitch	Synchronous motor with thermoswitch	synchronous motor	Basic wiring diagram including options
				<p>Switch off in end position via two load-dependant switches to control e.g. three-way mixing valves.</p>
				<p>Switch off in end position via a load-dependent switch and a limit switch to control e.g. full-way valves without upper stop. Monitoring blocking in OPEN direction.</p>
				<p>Control of three-phase actuators with thermoswitch, Switch off in end position via two load-dependant switches to control e.g. three-way mixing valves. For motors without thermoswitch, the wiring to terminal 4 and 5 is not applicable.</p>
				<p>Control of three-phase actuators with thermoswitch, Switch off in end position via a load-dependent switch and a limit switch to control e.g. full-way valves without upper stop. Monitoring blocking in OPEN direction. For motors without thermoswitch, the wiring to terminal 4 and 5 is not applicable.</p>

- WE Limit switch
- HZ Heater with thermoswitch
- POT Potentiometer
- ESR Electronic position feedback
- PEL Positioning electronics
- WSE External reversing contactor unit
- REG Process controller

DIMENSIONS

EL20 - EL45- EL80 – EL120

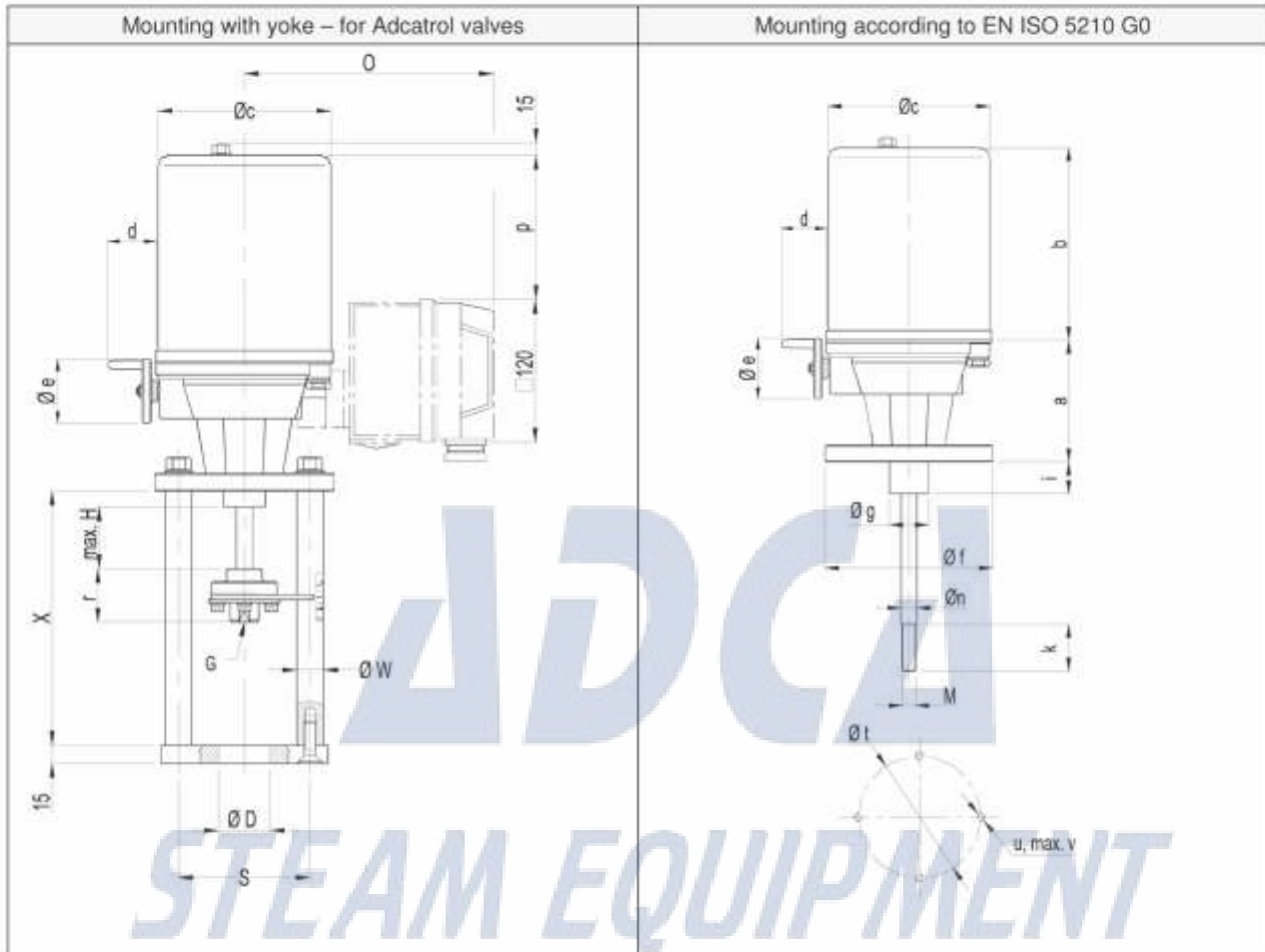

DIMENSIONS							
Type	EL20- EL45	EL80 - EL120	EL250	Type	EL20 - EL45	EL80 - EL120	EL250
a	94.5	130	190	o	210	220	240
b	173	197	226	p	115	179	164
Ø c	145	188	216	r	45	45	51
d	42	69	70	Ø w	22	22	22
Ø e	54	100	100	M		M16x1,5	M20x1,5
Ø f	74	130	130	max. G	M20	M20	M20
Ø g	35 18	60	60	Ø D	Ø 40, Ø 45	Ø 40, Ø 45	Ø 45, 65
i	3	26	3	G	M10	M10	M16
k		16	22	S	110 (100)	110 (100)	125
n	14	20	26	X	190 - 228		235
Ø t	50	102	102				
u	M6	M10	M10				
v							
H	Stroke actuators (see technical data)						

Specification is subject to change without prior notice

DIMENSIONS

EL12

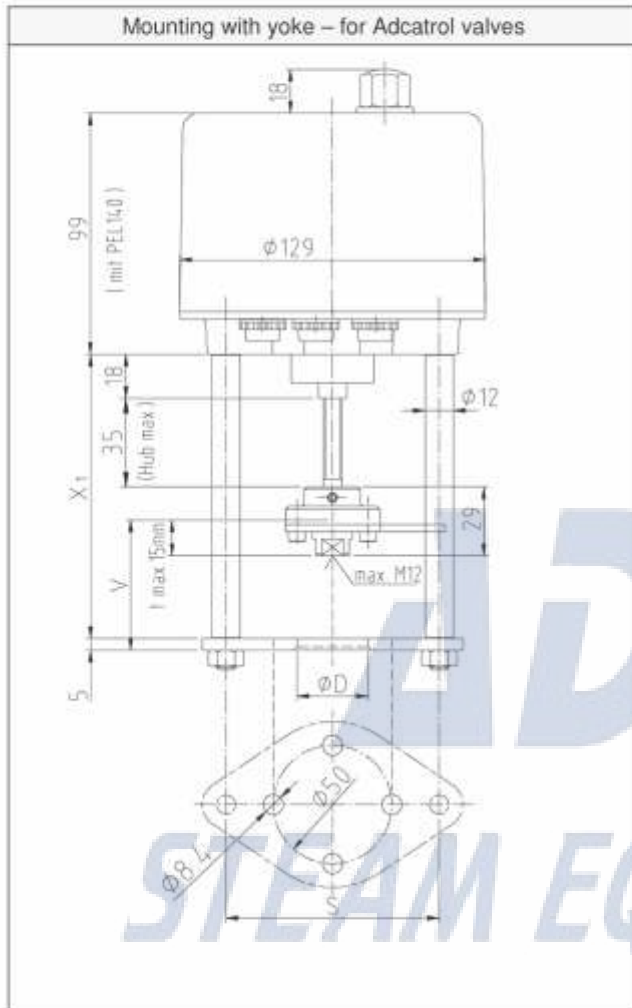

Type	EL 12
Ø D	40
S	100
X1	160
X2	55

COMBINATION WITH A CONTROL VALVE (short instruction)

On delivery the driving rod (1) is driven out to the bottom end limit (anti-rotation flange at bottom mark).

Further procedure:

- Insert valve stem (4) into the valve all the way to limit stop
- Move the driving rod (1) up by rotating the hand wheel anti-clockwise by about 20 mm (see manual operation).
- Lift the actuator and yoke over the valve stem, place onto the top of the valve and secure using the mounting nut (9)
- Unscrew the locking plate (3) and the anti-rotation flange (8) in succession from the coupling flange (2) and allow it to fall over the stem.
- Remove the threaded socket (6) from the coupling flange and screw it onto the stem according to dimension L from table 1.
- Drive out the rod by rotating the hand wheel clockwise until the threaded socket (6) stops in the coupling flange (2).

Screw the anti-rotation flange (8) and the locking plate (3) onto the coupling flange

-Tighten the stem with the nut (5) against the threaded socket.

- When mounting pay attention that the valve plug is not pressed onto the seat and is not turned.

For electrical connections please report to IMI EL20.00

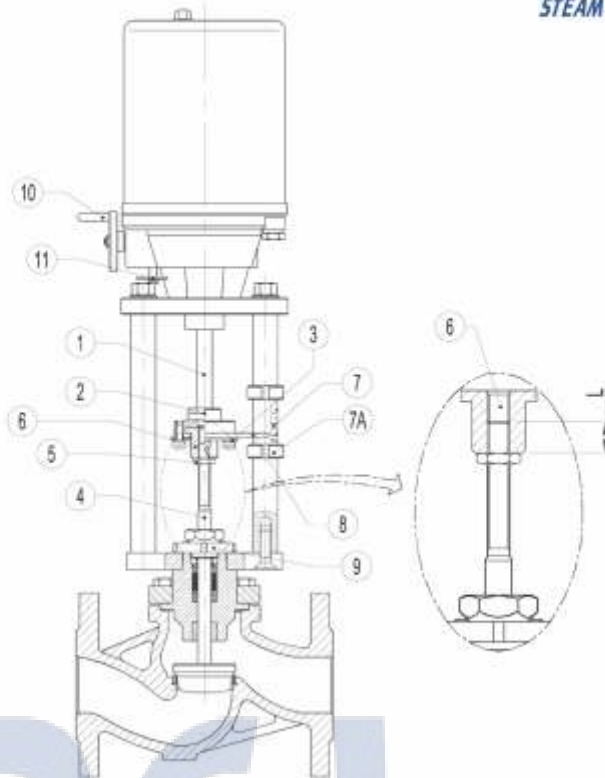

MANUAL OPERATION

The manual adjustment must not be disengaged or engaged while the motors is running.

Execute the manual adjustment only with motor being at standstill, hereto:

- With the left hand press the disengaging rod (11) with plate in direction of the outgoing driving rod toward the bottom
 - Simultaneously turn the handwheel (10) with the right hand until the coupling-in has sensible been executed
 - To actuate the linear actuator now turn the handwheel, hold the disengaging rod with the plate in engaged position
 - Turning crank handle to the right (clockwise), the driving rod moves out of the actuator
 - Turning crank handle to the left (anti-clockwise), the driving rod moves into the actuator
- (The linear actuator is automatically switched back to motoric operation, as soon as the disengaging rod will be released).

(L) Dimensions in mm

Valve Type	DN15	DN20	DN25	DN32	DN40	DN50	DN65	DN80	DN100	DN125	DN150	DN200
EV16G	18	18	18	13	12	14	25	25	19	-	-	-
EV40S	18	18	18	13	12	14	25	25	19	-	-	-

Table1

Actuator selection for two way valves type EV16G, EV25G and EV40S

Actuator Type	Differential pressure (bar)											
	DN15	DN20	DN25	DN32	DN40	DN50	DN65	DN80	DN100	DN125	DN150	DN200
EL12	38	20	12	6,5	3,5	1,8	-	-	-	-	-	-
EL20	40	40	28	16	9,9	5,8	3	1,7	0,6	-	-	-
EL45	40	40	40	40	29,8	18,5	10,5	6,6	3,8	-	-	-
EL60	40	40	40	40	40	36,4	21	13,6	8,2	-	-	-
EL120	-	-	-	-	40	40	33,1	21,6	13,3	8,3	5,6	3
EL250	-	-	-	-	-	-	40	40	30,2	19,1	12,1	5,5

Remarks: V-rings stem packing.

Actuator selection for three way valves type EV253G and EV403S

Actuator Type	Differential pressure (bar)											
	DN15	DN20	DN25	DN32	DN40	DN50	DN65	DN80	DN100	DN125	DN150	DN200
EL12	25	22	13,2	7,1	3,8	1,9	-	-	-	-	-	-
EL20	25	25	25	17,3	10,8	6,6	3,4	2	1,1	-	-	-
EL45	-	-	-	25	25	19,8	11,6	7,3	3,8	2,4	1,5	-
EL60	-	-	-	-	25	25	23,1	14,8	8,9	5,5	3,6	-
EL120	-	-	-	-	25	25	25	23,1	14,5	9,1	6,1	-
EL250	-	-	-	-	-	-	-	-	-	-	-	-

Specification is subject to change without prior notice