

MODEL : 100M [Straight Way Diaphragm Valve]

Connection : Flange PN 10, ANSI 150



◆ FEATURES

1. Design and manufacture confirm to BS5156
2. Flange dimensions confirm to BS4504 PN10
3. Working pressure: -DN50-100 1.0Mpa
-DN125-150 0.6Mpa
-DN200-300 0.35Mpa

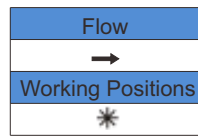

◆ MATERIAL LIST

| NO. | PART | MATERIAL | QTY |
|-----|-------------|-----------------|-----|
| 1 | BODY | GG25 | 1 |
| 2 | BODYLINED | PTFE | 1 |
| 3 | DIAPHRAGM | PTFE | 1 |
| 4 | VALVE CLACK | GG25 | 1 |
| 5 | BONNET | GG25 | 1 |
| 6 | STEM | STAINLESS STEEL | 1 |
| 7 | BUSH | PLASTIC | 2 |
| 8 | HANDWHEEL | GGG40 | 1 |

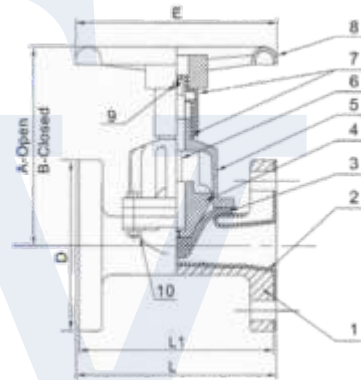

◆ DIMENSIONS (mm)

| DN | L | L1 | A | B | D | E | Weight (Kg) |
|-----|-----|-----|-----|-----|-----|-----|-------------|
| 50 | 194 | 190 | 185 | 165 | 165 | 160 | 8.5 |
| 65 | 222 | 216 | 224 | 200 | 185 | 200 | 16 |
| 80 | 258 | 254 | 273 | 240 | 198 | 250 | 22 |
| 100 | 309 | 305 | 321 | 285 | 220 | 315 | 32 |
| 125 | 362 | 356 | 347 | 305 | 250 | 315 | 43.5 |
| 150 | 412 | 406 | 447 | 385 | 283 | 400 | 65 |
| 200 | 527 | 521 | | 415 | 335 | 500 | 112.5 |
| 250 | 640 | 635 | | 560 | 400 | 500 | 192.5 |
| 300 | 755 | 749 | | 640 | 460 | 630 | 296 |

Specification is subject to change without prior notice