

**BIMETALLIC STEAM TRAPS AND AIR ELIMINATORS
BM24
(1/2" – 1"; DN 15 – 25)**

DESCRIPTION

BM24 series bimetallic steam traps and air eliminators are simple and robust traps, recommended for steam process applications where condensate sensible heat can be recovered, steam tracing lines, drip points, storage tank coils, steam air venting, etc. The use of condensate sensible heat reduces steam consumption.

Connections are female screwed or flanged.

MAIN FEATURES

- Modulating discharge.
- Discharges condensate below steam temperature.
- Excellent air discharge.
- Operates on superheated steam.
- Unaffected by water hammer and vibrations.
- Built-in strainer.



- OPTIONS:** Blowdown valve.
- USE:** Saturated and superheated steam.
- AVAILABLE MODELS:** BM24.
- SIZES:** 1/2" to 1"; DN 15 to DN 25.

- CONNECTIONS:** Female screwed ISO 7/1 Rp (BS21).
Flanged EN 1092-1 PN40 or ANSI.

- INSTALLATION:** Horizontal installation recommended, can be installed in any position.
See IMI installation and maintenance instructions.

BODY LIMITING CONDITIONS		
FLANGED PN40 / ANSI 300 lb *	FLANGED ANSI 150 lb **	RELATED TEMP.
ALLOW. PRESS.	ALLOW. PRESS.	
40 bar	19,3 bar	50 °C
35 bar	15,8 bar	150 °C
30,4 bar	12,1 bar	250 °C
27,6 bar	10,2 bar	300 °C

PMO – Max. operating pressure 24 bar
TMO – Max. operating temperature 250 °C
* According to EN1092-1:2018; ** Acc. to EN1759-1:2004;
Body limiting conditions PN40 or below, depending on the type of connection adopted.
Rating PN40 for thread, SW and BW.

CE MARKING – GROUP 2 (PED – European Directive)	
PN40	Category
DN 15 to DN 25	SEP

FLOW RATE CAPACITY (kg/h)															
MODEL	SIZE	DIFFERENTIAL PRESSURE (bar)													
		0,5	1	2	4	6	8	10	12	14	16	18	20	22	24
BM24	1/2" to 1" A DN 15 – 25 A	225	350	490	650	720	795	820	850	880	900	905	910	915	925
BM24	1/2" to 1" B DN 15 – 25 B	550	800	1100	1500	1750	1825	2000	2100	2175	2235	2390	2490	2585	2680

A: Condensate discharge at 10 °C below saturation temperature; **B:** Cold water capacity around 20 °C.

MODEL : BIMETALLIC STEAM TRAPS AND AIR ELIMINATOR

DIMENSIONS (mm)											
Screwed and SW *						PN16/40		ANSI 150 lb		ANSI 300 lb	
Size	A	B	C	D	WGT. (kg)	E	WGT. (kg)	E	WGT. (kg)	E	WGT. (kg)
1/2" – DN 15	95	59	95	90	2,1	150	3,7	150	3,2	150	4
3/4" – DN 20	95	59	95	90	2,1	150	4,5	150	3,7	150	5,3
1" – DN 25	95	65	95	90	2,1	160	4,9	160	4,5	160	6,1

* BW (butt weld) on request.

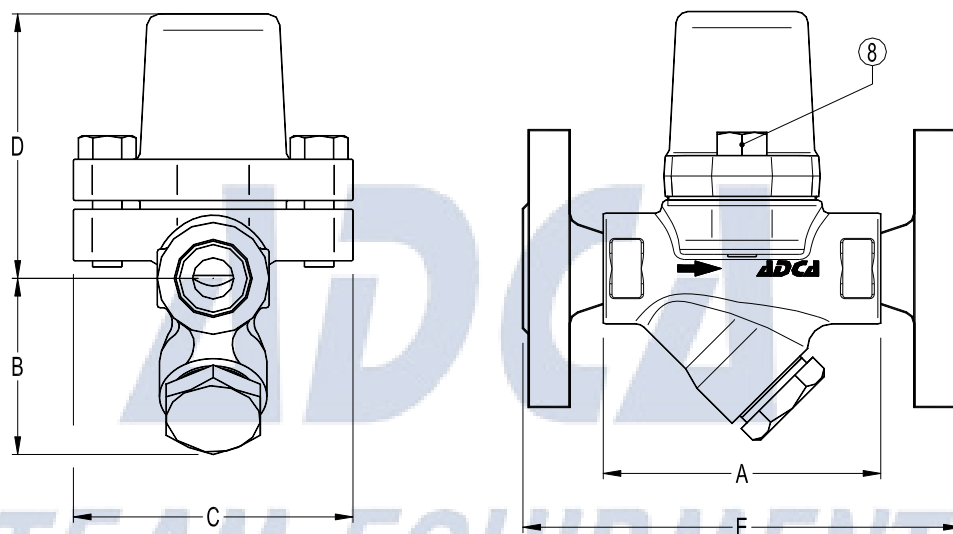

MATERIALS		
POS. N°	DESIGNATION	MATERIAL
1	Body	P250GH / 1.0460
2	Cover	P250GH / 1.0460
3	* Gasket	Stainless steel / Graphite
4	* Valve assembly	Bimetal
5	* Strainer screen	AISI 304 / 1.4301
6	* Strainer cover	A 105 / 1.0432
7	* Gasket	Stainless steel / Graphite
8	Bolts	A2-70

* Available spare parts.

